

# Microwave Transistor Power Rectifiers and Applications

Zoya Popovic, Ignacio Ramos, Tibault Reveyrand, Michael Litchfield

Department of Electrical, Computer and Energy Engineering, University of Colorado  
Boulder, CO 80309-0425, U.S.A., (303) 492-0374, [zoya@colorado.edu](mailto:zoya@colorado.edu)

**Abstract** — This paper presents design, analysis and experimental results on synchronous and self-synchronous microwave transistor rectifiers implemented with GaN HEMTs at frequencies from 2 to 10GHz. The rectifier/power amplifier duality is explained and measurements confirming this mode of operation are presented. Finally, rectifier applications in wireless power transfer and high-frequency integrated dc-dc converters are discussed, including a GaN MMIC dc-dc converter switching at 4.6GHz.

**Index Terms** — GaN HEMT, rectifier, class-E, power amplifiers, high efficiency.

## I. INTRODUCTION

Microwave rectifiers are elementary circuits in applications such as wireless power transfer [1] and dc-dc converters [2]. Although rectifiers are most often designed with diodes at microwave frequencies, GaN HEMTs offer advantages for higher power rectifiers used in MMIC subsystems, such as integration of PAs and rectifiers in dc-dc converters [2], [3] or in energy recovery for outphasing amplifiers [4], [5], [6].

It has been shown that under certain loading, a microwave transistor can achieve similar efficiencies as both a power amplifier and a rectifier [7,8] due to its time-reversal duality property [9]. In this paper, an overview of microwave transistor rectifier operation, design, characterization and applications is presented.

## II. POWER RECTIFIER-AMPLIFIER DUALITY

A very interesting result discussed in this section relates to the duality between rectifiers and power amplifiers (PAs). Assume a PA operating in some high-efficiency mode has an RF output power  $P_{OUT}$  at a supply voltage of  $V_D$  and appropriate gate drive and bias. If now the drain supply is disconnected and an RF power  $P_{IN} = P_{OUT}$  input into the RF drain port, the PA will behave as a rectifier with a conversion efficiency equal to the power-added efficiency of the PA,  $\eta = PAE$ . Furthermore, the output DC voltage  $V_{DC} = V_D$  across some optimal DC load  $R_D$ , assuming the gate bias and input drive conditions are kept the same. This is illustrated in Fig.1 and is referred to as time-reversal duality, where the drain voltages and

currents in the two circuits are the negatives of each other and satisfy:  $v_{PA}(t) = v_R(-t)$ , and  $i_{PA}(t) = -i_R(-t)$ .

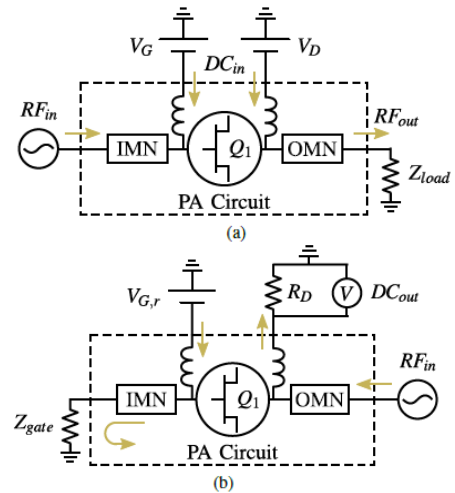

Fig. 1. PA-rectifier duality: (a) PA circuit and (b) rectifier circuit. In this case, the rectifier is operating self-synchronously with no RF input at the gate.

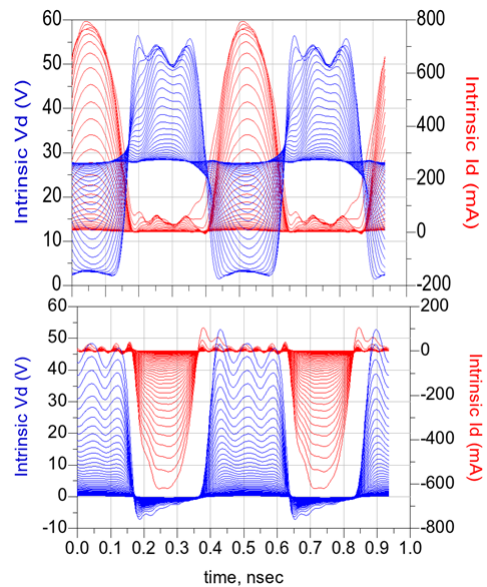

Fig.2. Simulated time-domain waveforms for a class-F PA (top) and rectifier (bottom), showing time-reversal duality.

Synchronous operation of the rectifier requires a second RF source to drive the gate of the transistor to turn it on [10]. Self-synchronous operation relies on power coupled from the drain to the gate through the shared capacitance,  $C_{gd}$ . With a highly reflective termination,  $Z_{gate}$ , the coupled power can be reflected into the gate to turn on the transistor without a second RF source [8].

Simulations using a unique nonlinear model that includes the 3<sup>rd</sup> quadrant of the I-V curves [11] results in time-domain waveforms as shown in Fig.2 [9]. This holds true for any class of PA, not just the to-date-demonstrated classes F [9], F<sup>-1</sup>[8] and E [3].

In [8], a theoretical analysis of harmonically terminated high-efficiency power rectifiers is presented. The theory is based on a Fourier analysis of current and voltage waveforms, which arise across the rectifying element when different harmonic terminations are presented at its terminals, in analogy to harmonically terminated PA theory. From the analysis, one can obtain an optimal value for the dc load given the RF circuit design. An upper limit on rectifier efficiency is also derived as a function of device on-resistance.

### III. EXAMPLE GAN RECTIFIERS

In this section, some results for demonstrated GaN self-synchronous rectifiers at S and X bands are reviewed. A 2.14-GHz PA is designed using the Qorvo TGF2023-02 GaN HEMT with class-F<sup>-1</sup> harmonic terminations implemented at the second and third harmonics [8]. The PA was characterized at 2.14GHz with a drain voltage bias of 28V and a bias current of 160mA, and exhibited PAE=84% with  $P_{OUT}$ = 37.6 dBm and a gain of 15.7 dB under 3-dB compression.

The same PA was then characterized as a rectifier, as in Fig.1b, with the gate biased and connected to an impedance tuner, converting the two-port transistor PA to a one-port rectifier. The measured results are summarized in Figs. 3 and 4. Fig.3 shows the dependence on gate impedance termination  $Z_{gate}$  under self-synchronous operation. The rectifier demonstrates an efficiency of 85% for a 10-W input RF power at the transistor drain with a dc voltage of 30 V across a 98-Ω resistor, demonstrating PA-rectifier duality.

To further validate time-reversal duality, two high-efficiency GaN MMIC PAs are characterized under PA and rectifier operation [7] at X-band, Fig.5. Both MMICs are designed in Qorvo's 150nm GaN-on-SiC process; A is a single-stage amplifier using a 10x100μm transistor biased at pinch-off ( $I_{DQ}$ =5mA), with an output matching network optimized for efficiency, but with no specific harmonic terminations. B is a single-stage amplifier that

combines two 10x100μm transistors, biased in deep class-AB, with a reactive combiner. The MMIC performance is summarized in the table as the dc load on the drain is varied along with input power. Similar characterization is performed with gate bias variation and it was found that deep pinch-off improves the efficiency by 12 and 6.2 points in the two rectifiers respectively, but has little effect on the input impedance.

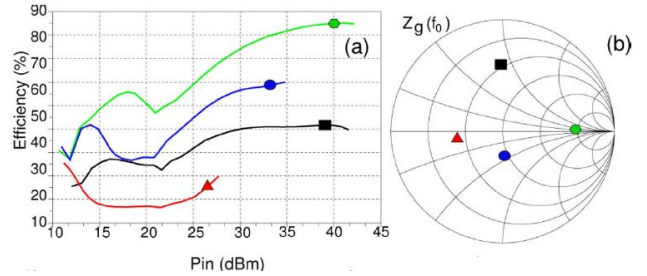

Fig. 3. Conversion efficiency for several RF load impedances presented at the gate.  $V_G$ =-4.4V and  $R_{DC}$ =98Ω. The green point on the Smith chart corresponds to the highest efficiency point at  $Z_{gate}$ = 230+j10Ω.

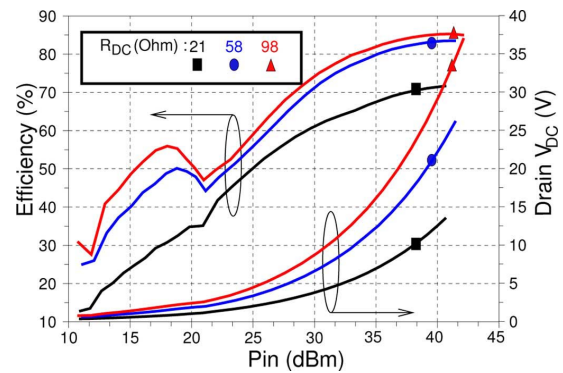
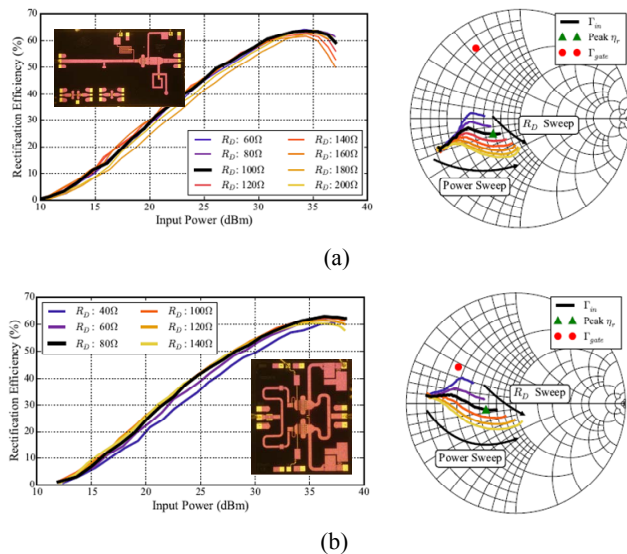

Fig.4. Conversion efficiency and drain dc output voltage versus input power for several dc drain resistor values.  $V_G$ =-4.4V and  $Z_{gate}$ = 230+j10Ω. The highest efficiency of 85% is obtained at 40dBm with a  $V_D$ =30V.

Table I summarizes the performances of the two X-Band GaN MMICs operating as both amplifiers (PAE) and rectifiers (conversion efficiency). In both modes, the RF power is the power located at the RF drain port, because the duality of these modes states that the output power of the amplifier should be the required input power of the rectifier for peak rectification efficiency. The DC load at the drain is 100Ω.

The PA-rectifier duality is very general and also applies to two-stage PAs [10]. A 2-stage X-band GaN MMIC PA, biased in class AB, achieves over 10W of output power, >20dB of saturated gain and a PAE of 50% at 9.9GHz. Over 52% RF-DC conversion efficiency at a power level of >8W is measured in rectification, Fig.6.



MMIC	PAE	Drain eff.	P <sub>OUT</sub>	G <sub>SAT</sub>
PA-A	68%	79%	34.8dBm	8.9dB
PA-B	63%	77%	35.4dBm	6.3dB

Fig.5. Measured rectification efficiency and input impedance of the rectifier under input power and dc drain impedance sweeps for (a) single-ended PA and (b) power combined PA at 10.7GHz.

Table I. Comparison of amplifier and rectifier

Circuit	Amplifier		Rectifier	
	A	B	A	B
Max Efficiency(%)	67.87	56.47	64.40	63.94
DC Power (mW)	4186	5112	1671	3182
RF Power (mW)	3281	3362	2594	4976

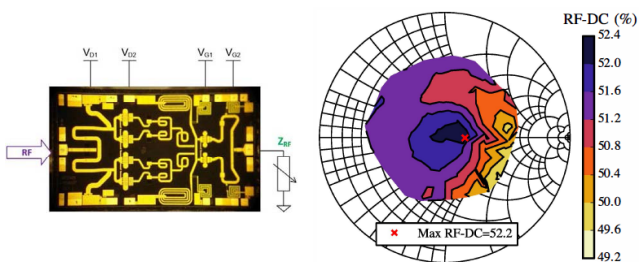

Fig.6. Two-stage MMIC PA configured as rectifier (left) and measured (right). Total RF-DC contours showing how the RF load affects system efficiency. A maximum PAE of 52.2% is achieved at  $Z_g=69-j0.4\Omega$  [10].

#### IV. APPLICATIONS OF POWER RECTIFIERS

Several applications of GaN HEMT self-synchronous rectifiers are reviewed next: (1) dc-dc converters at 1.2 and 4.6GHz [3]; (2) outphasing amplifier with power recycling [11]; and (3) wireless power transfer [12].

With increasing voltages and power densities enabled by wide-bandgap semiconductors, monolithic integration towards a chip-scale power supply becomes a possibility. Higher switching frequencies are accompanied by reduced efficiency and power since the losses in both passive and active components increase with frequency. Over two decades ago, as high as 64% efficiency was obtained with GaAs devices in a circuit based on transmission lines only, operating at 4.6GHz at sub-watt power [13], with both a power amplifier and a power oscillator as the inverter stage. In [3], dc-dc converters implemented with a PA using a 0.25μm Qorvo GaN die as the dc-ac stage (inverter) and a time-reversed dual rectifier with a resonant dc-isolated coupling network are demonstrated around 1GHz. The converters have no magnetic components and operate in class-E mode, Fig. 7, which was tested in synchronous, self-synchronous and oscillating self-synchronous modes, with two, one and no RF inputs, respectively. The self-synchronous results are shown in Fig.7 at 1.2GHz, demonstrating 75% efficiency at 5W [3].

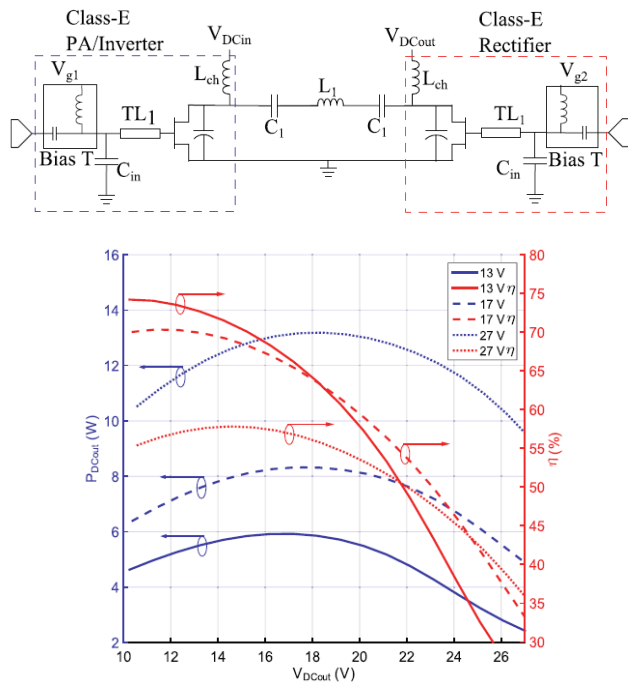

Fig. 7. Circuit diagram and measured total efficiency of class-E<sup>2</sup> self-synchronous dc-dc converter at 1.2GHz [3].

The same architecture was integrated in the 150-nm GaN process at 4.6GHz [14], with a decreased efficiency due to the increased switching losses at this frequency. Nevertheless, this 2.3mm x 3.8mm integrated converter is fully monolithic with no magnetic components, Fig.8. The

total efficiency of around 50% indicates that both rectifier and amplifier are operating at >70% efficiency.

Another application of PA-rectifier duality is illustrated in Fig.9 where an outphasing PA with isolated combining incorporates a rectifier at the rat-race isolated port. The MMIC achieves  $\eta_{tot} > 50\%$  and  $P_{OUT} > 5W$  over at least 400MHz bandwidth and 65% at 6W at 10.35GHz. If the rectified dc power is included, an 8.1 point improvement in efficiency at 3.5dB backoff is achieved, Fig.9.

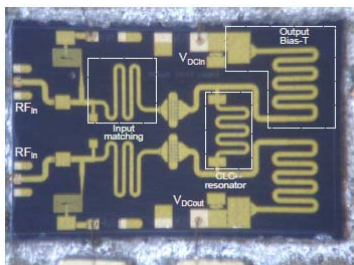

Fig. 8. Fully integrated class-E dc-dc converter [14].

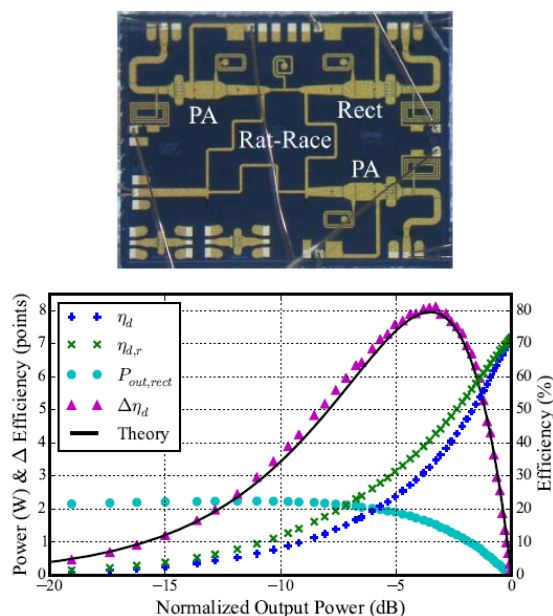

Fig.9. Photo of implemented outphasing MMIC with power recycling (top). The measured improvement in efficiency when taking the rectified power into account as a function of output power backoff (bottom) agrees well with theory [11]. The efficiency at 10.3GHz is >60% ( $P_{out}=6W$ ), with an improvement of 8.1 points at 3.5dB backoff.

Finally, the dc-dc converter topology from Fig.7 can be also applied to wireless powering, where the coupling circuit is an electromagnetic field. When using PA/rectifier duality, a bidirectional wireless power transfer is accomplished in a straightforward manner [12].

In summary, basic properties, experimental validation and several applications of self-synchronous GaN HEMT rectifiers are demonstrated from 1 to 10GHz.

#### ACKNOWLEDGMENT

This work was funded by the DARPA MPC program through ONR (N00014-11-1-0931) and ARPA-E (DE-AR0000216). Z. Popovic acknowledges funding from the Hudson Moore Jr. Endowed Chair at the University of Colorado, and support by National Instruments for unique measurement development that was required for this work.

#### REFERENCES

- [1] Z. Popovic, "Low-Power Far-Field Wireless Powering," *IEEE Microwave Magazine*, vol. 14, pp. 55–62, Mar. 2013.
- [2] J. A. Garcia, et al. "GaN HEMT Class E<sup>2</sup> Resonant Topologies for UHF DC/DC Power Conversion," *IEEE Trans. Microwave Theory Techn.*, vol. 60, pp. 4220–4229, Dec. 2012.
- [3] I. Ramos et al., "GaN Microwave dc-dc Converters," *IEEE Trans. Microwave Theory Techn.*, vol.63, pp. 4473–4482, Dec. 2015
- [4] R. Langridge et al., "A power reuse technique for improved efficiency of outphasing microwave power amplifiers," *IEEE Trans. Microwave Theory and Techniques*, vol. 47, pp. 1467–1470, 1999.
- [5] P. Godoy et al. "Outphasing Energy Recovery Amplifier With Resistance Compression for Improved Efficiency," *IEEE Trans. Microwave Theory Techn.*, vol. 57, pp. 2895–2906, Dec. 2009.
- [6] J. Xu et al., "An Efficient, Watt-Level Microwave Rectifier Using an Impedance Compression Network with Applications in Outphasing Energy Recovery Systems," *IEEE Microw. Wireless Comp.Lett.*, pp.542–544, 2013.
- [7] M. Litchfield, T. Reveyrand, Z. Popovic, "High-efficiency X-band MMIC GaN power amplifiers operating as rectifiers," *2014 IEEE IMS*, June 2014, pp. 1–4.
- [8] M. Roberg et al., "High Efficiency Harmonically Terminated Diode and Transistor Rectifiers," *IEEE Trans. Microwave Theory Techn.*, vol. 60, pp. 4043–4052, Dec. 2012.
- [9] T. Reveyrand, I. Ramos, Z. Popovic, "Time-reversal duality of high efficiency RF power amplifiers," *Electronics Lett.*, vol. 48, pp. 1607–1608, Dec. 2012.
- [10] M. Coffey et al., "Two-stage high-efficiency X-Band GaN MMIC PA/ rectifier," *IEEE IMS 2015*, 17-22 May 2015
- [11] M. Litchfield, Z. Popovic, "X-band outphasing GaN MMIC PA with power recycling," *IEEE IMS*, 17-22 May 2015
- [12] S. Schafer et al., "X-band wireless power transfer with two-stage high-efficiency GaN PA/ rectifier," *IEEE WPTC 2015*, 13-15 May 2015
- [13] S. Djukic et al. "A planar 4.5-GHz DC–DC power converter," *IEEE Trans. Microw. Theory Techn.*, vol. 47, no. 8, pp. 1457–1460, Aug. 1999.
- [14] I. Ramos et al., "A Microwave Monolithically Integrated Distributed 4.6 GHz DC-DC Converter", *IEEE IMS 2016*.